



APPLICATIONS

- Gymnasium
- Warehouses
- Shopping Centers
- Indoor Spaces
- Commercial
- Industrial Areas
- Hotels
- Toll Stations
- Garages
- Hotels

Description :

This residential downlights are inexpensive, durable, and are available in 4" , 5" , 6".
CCT- 3000K , 4000K , 5000K

Installation :

MC cables and junction box allow for flexibility during installation process.

Electrical :

dimnable

Construction :

Polycarbonate driving housing with aluminum reflector, and fire proof junction box

SPECIFICATION

ORDER NUMBER	PT-DL-6I/12W-3CCT
LIFESPAN	50,000 HRS
IP RATING	44
BEAM ANGLE	100 °
THD	20%
WEIGHT	2LBS
WATTAGE	12W
CCT	3000K / 4000K / 5000K
LUMENS	950lms/1000lms/1050lms
CRI	>90
LIGHT EFFICIENCY	>85lumens/watt
DIMMING	YES
VOLTAGE	AC120V
POWER FREQUENCY	50 Hz
LED DRIVER	WeLedPower
WORKING TEMPERATURE	-40°F - +122°F
Power Factor	0.9
CERTIFICATIONS	ETL, FCC, CE, Energy Star

PRODUCT INFORMATION

DIMENSION

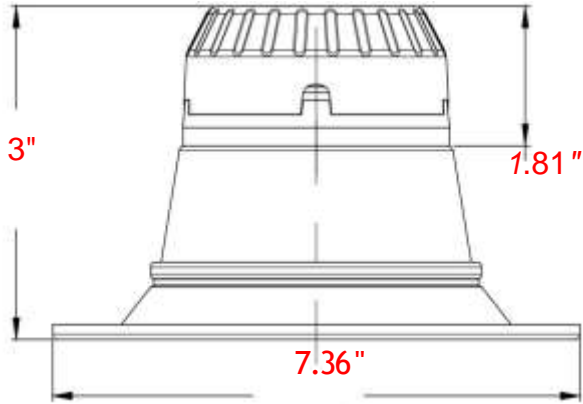

PHOTOMETRICS

LUMINOUS INTENSITY DISTRIBUTION DIAGRAM

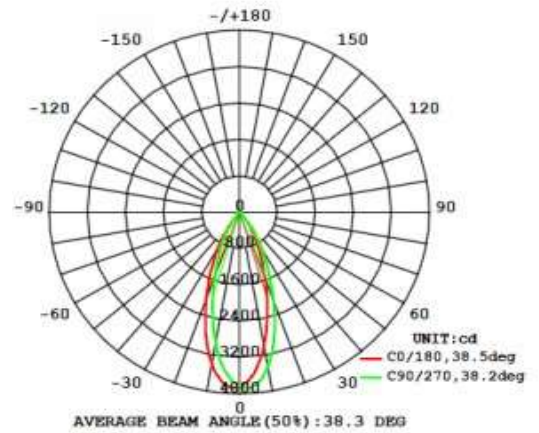

PLANAR ISOLUX DIAGRAM (UNIT: 1x)

